

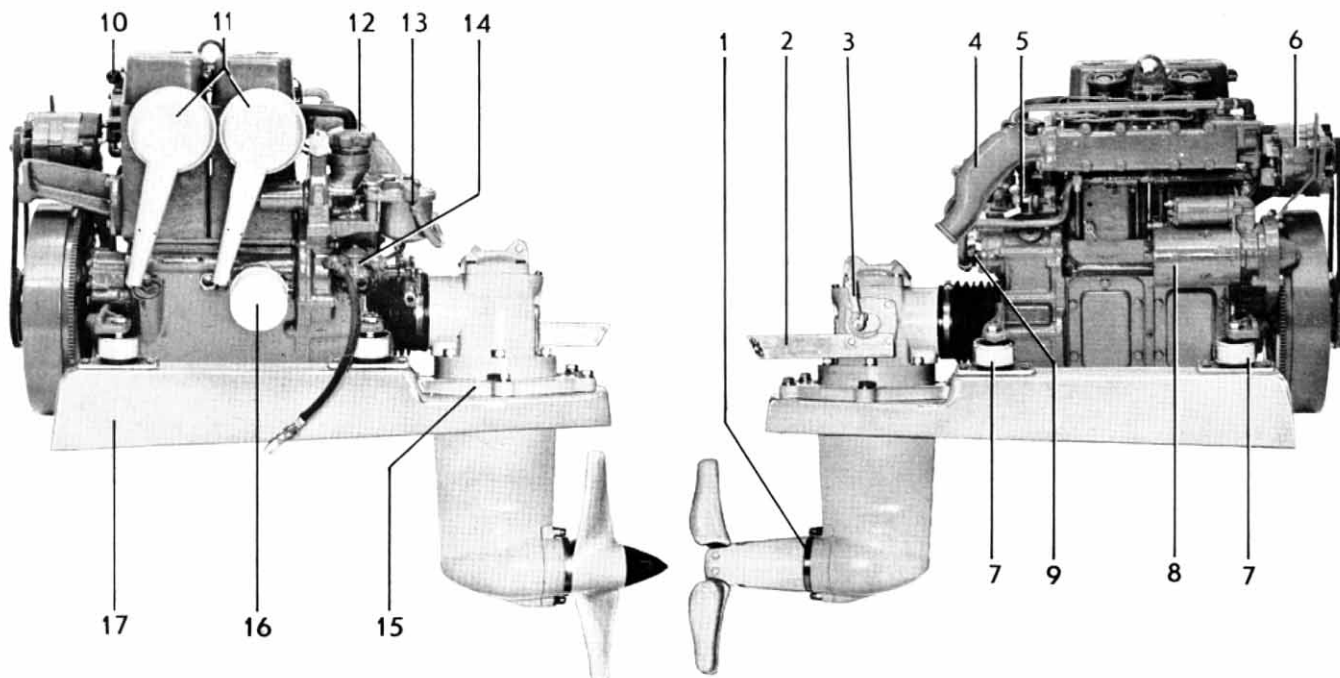

MD 11C/100S



2-cylinder, 4-stroke marine diesel engine with direct injection and sailboat drive 100S
Propeller shaft output 17 kW (23 hp)



STANDARD EQUIPMENT

ENGINE BODY – Cylinder block and head made of cast iron. Replaceable cylinder liners. Pistons made of light-alloy with 3 compression rings and one oil scraper ring. Crankshaft journalled in 3 bearings. Decompression handle (10).

Tool kit is supplied with engine.

Bed of glass-fibre reinforced plastic with installation parts (17).

FUEL SYSTEM – Piston-type injection pump with centrifugal governor for accurate speed regulation (5).

Feed pump with hand primer (14) and flexible hose with fuel pipe connection.

Effective fuel filter (13).

Manual cold-starting device.

Stop lever with bracket for push-pull mechanism.

COOLING SYSTEM – Thermostat-controlled sea-water cooling. Sea-water pump with neoprene rubber impeller (9).

LUBRICATING SYSTEM – Pressure-lubrication system with lubricating oil filter of the spin-on type (16). Oil filling (12) and sealed crankcase ventilation.

INTAKE SYSTEM – Intake selencers (11) with filter.

EXHAUST SYSTEM – Sea-water cooled exhaust manifold of cast iron. Exhaust manifold elbow for hose connection (4). Through-hull fitting for exhaust line.

ELECTRICAL SYSTEM – Corrosionsprof 12 V electrical system, with complete instrument panel.

Alternator 34 A, 420 W (6). Starter motor output 1.5 kW (2 h.p.) (8).

The instrument panel is provided with a key switch, rev counter, temperature gauge, warning lamps for battery charging and oil pressure, a switch for instrument lighting and 1 extra switch. Cable harness, 4 m (13 ft.) in length, with connector.

Main fusing with built-in spare fuse is supplied.

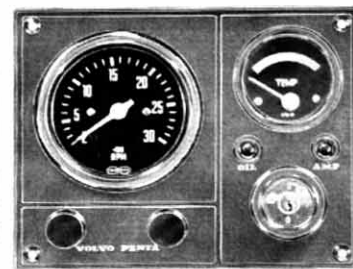

ENGINE MOUNTING – The engine is supplied with flexible engine mounting (7).

SAIL BOAT DRIVE – Complete with attachments against the bed (15). Silent Shift cone clutch (patented) ensures reliability in operation and quiet engagement with small manoeuvring forces. Both speed and manoeuvring are operated by one and the same control lever. Bracket for control cable (2). Lever for shift mechanism (3). Protective ring of zinc which prevents corrosion (1).

EXTRA EQUIPMENT

FUEL SYSTEM

Electrically operated fuel pump
Cold starting device, mechanical
Cold starting device, electrically operated
Water-separating filter with or without flexible hoses
Water separator
Fuel tank
Cap with connections for fuel tank
Fuel line kit with copper piping and installation parts

COOLING SYSTEM

Sea-water filter complete with attachment
Cooling water intake complete with cock and hose
Vacuum valve

EXHAUST SYSTEM

Exhaust rubber hose

Water-cooled silencer, complete

ELECTRICAL SYSTEM AND INSTRUMENTS

Charging distributor for charging 2-battery system
Extra instruments: Hourmeter, fuel- and water gauge, voltmeter, rudder indicator.
Master switch
Cable harness extension
Instrument panel for extra instrument
Automatic alarm for oil pressure and water temperature

SAILBOAT DRIVE

Extension 1"

BOAT ACCESSORIES

Electrically operated bilge pump
Original paint
Oils

CONTROLS AND CONTROL SYSTEM

VP single-control lever for both speed and forward-reverse operation, top-mounted or side-mounted.
Neutral-position switch — automatic safety interlock for VP controls
Push-pull controls
Control cables
Steering gears
Steering lock
Steering wheels
Steering cables
Ball joint and fork for steering cables

PROPELLERS

2-blade foldable 15"x10,5"
2-blade 16"x11"
3-blade 14"x12"
3-blade 14"x11"

DATA

Type of operation 4-stroke diesel engine with direct injection
Designation MD11C/100S
Propeller shaft output¹⁾ 17 kW at 41.7 r/s (23 hp at 2500 rpm)
Number of cylinders 2
Capacity, dm³ (in³) 1.120 (68.4)
Bore, mm (in) 88.9 (3.5)
Stroke, mm (in) 90 (3.54)
Valves overhead
Sailboat drive model/ratio 100S/1.66:1
Weight, engine with sailboat drive, kg (lb), approx. 245 (540)

1) The diagram indicates the propeller shaft output for a run-in engine with sailboat drive according to DIN 6270 Leistung B für Dauerbetrieb. The engine flywheel output is approx. 4.5 % higher.

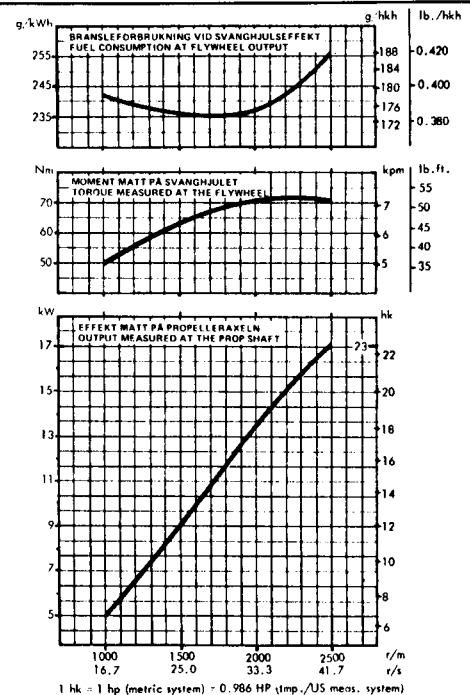

DIMENSION DRAWING

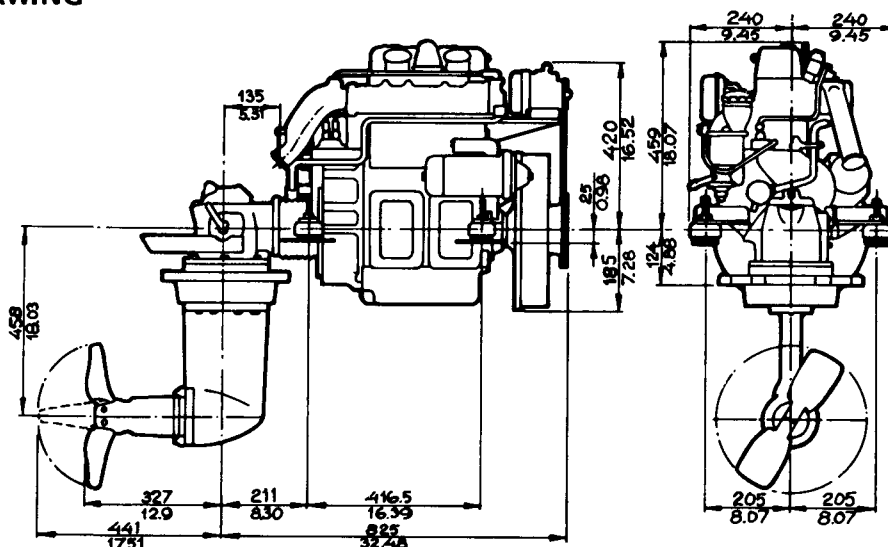

AB VOLVO PENTA

Box 392, S-401 26 Gothenburg 1, Sweden
Telephone: 031/23 54 60
Telegrams: Penta
Telex: 207 55

We reserve the right to carry out modifications

